

Rated Voltage : 12V/ 48V

Operating Temp : 10~70°C

Protection : Auto-Restart /Impedance

Material : Housing Plastic (UL : 94V-0)
Impeller Plastic (UL : 94V-0)

Weight : 139g

Safety Approval



AIR FLOW-AIR PRESSURE(PERFORMANCE CURVES)

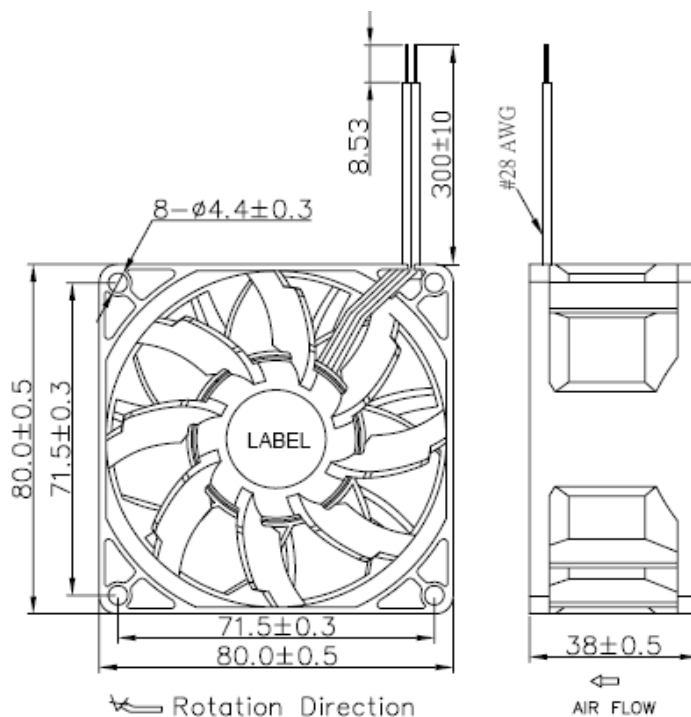
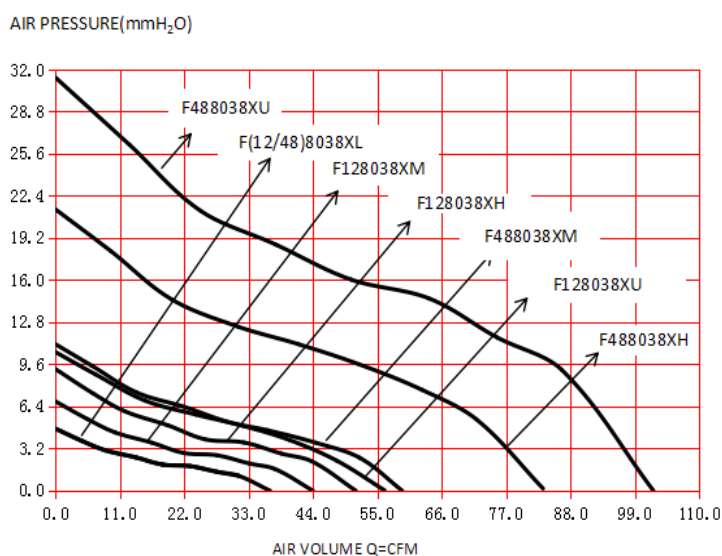

Series	Bearing (*)	Rated Voltage (V)	Rated Current (Amp)	Input Power (W)	Rated Speed (rpm)	Air Flow		Static Pressure (mmH ₂ O)	Noise dB(A)
						(CFM)	m ³ /min		
F128038XL	●	12	0.18	2.16	3000	36.65	1.04	4.71	35.0
F128038XM	●	12	0.25	3.00	3600	43.98	1.25	6.79	39.0
F128038XH	●	12	0.30	3.60	4200	49.75	1.41	7.85	43.9
F128038XU	●	12	0.50	6.00	4800	56.21	1.59	10.53	46.8
F488038XL	●	48	0.06	2.88	3000	36.65	1.04	4.71	35.0
F488038XM	●	48	0.10	4.80	5000	59.23	1.68	11.13	47.7
F488038XH	●	48	0.24	11.52	7000	83.27	2.36	21.37	57.0
F488038XU	●	48	0.50	24.00	8500	102.15	2.89	31.38	61.8

*Bearing Type : ○ Sleeve ▲ EBR ● 2 Ball

*Noise measured at the distance of one meter from the axis of intake.

*The latest version would be as per the standard issued by REGO only.