

Rated Voltage : 12V

Operating Temp : 10~70°C

Protection : Auto-Restart/ Impedance

Material : Housing Plastic (UL : 94V-0)  
Impeller Plastic (UL : 94V-0)

Weight : 29g

Safety Approval



AIR FLOW-AIR PRESSURE(PERFORMANCE CURVES)

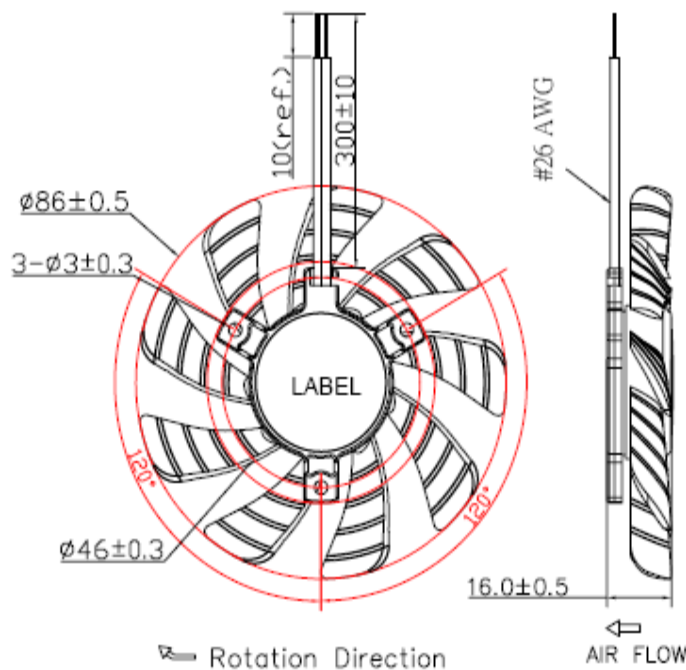
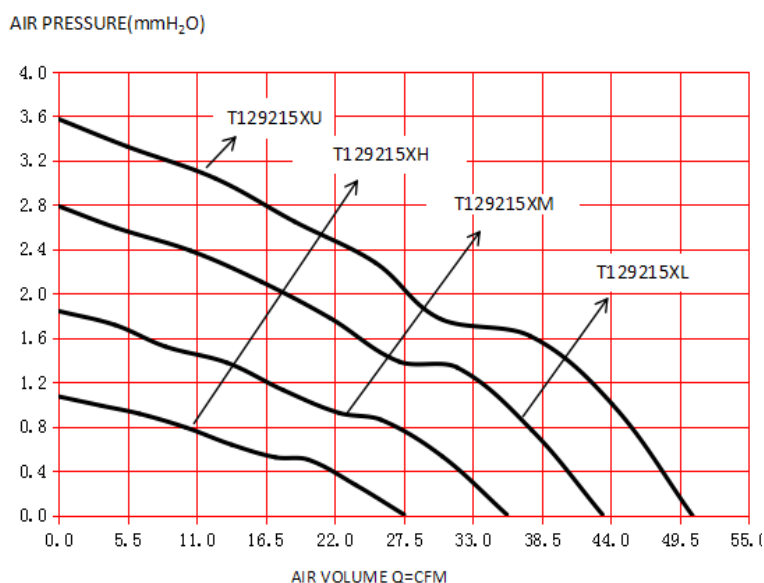

Series	Bearing (*)	Rated Voltage (V)	Rated Current (Amp)	Input Power (W)	Rated Speed (rpm)	Air Flow		Static Pressure (mmH <sub>2</sub> O)	Noise dB(A)
						(CFM)	m <sup>3</sup> /min		
T129215XL	▲●	12	0.07	0.84	2000	27.51	0.78	1.07	21.5
T129215XM	▲●	12	0.12	1.44	2500	35.70	1.01	1.84	28.3
T129215XH	▲●	12	0.20	2.40	3000	43.33	1.23	2.79	30.5
T129215XU	▲●	12	0.27	3.24	3500	50.51	1.43	3.57	34

\*Bearing Type : ○ Sleeve ▲EBR ●2 Ball

\*Noise measured at the distance of one meter from the axis of intake.

\*The latest version would be as per the standard issued by REGO only.